

# CI Study of Geometrical Relaxation in the Ground and Excited Singlet and Triplet States of Unprotonated Schiff Bases: Allylideneimine and Formaldimine

V. Bonačić-Koutecký\* and M. Persico†

Contribution from the Institut für Physikalische Chemie, Freie Universität Berlin, 1000 Berlin 33, West Germany. Received November 24, 1982

**Abstract:** The influence of rotations around C=C, C=N, and C—C bonds on the electronic structure of the four lowest valence singlet and three triplet states in allylideneimine has been investigated employing large-scale CI treatments. Also the in-plane inversion of the hydrogen attached to the nitrogen has been studied. The correlated wave functions have been analyzed in terms of covalent and ionic VB-like structures so that their characteristic features can be compared at found energy minima. Planar inversion yields the lowest barrier in the singlet ground state. The rotation and elongation of the C=C bond is not energetically favorable for the first singlet excited state  $S_1$  which develops from the  $n-\pi^*$  state and gains mixed covalent and ionic nature for the  $90^\circ$  twist. At this geometry a pair of polar zwitterionic states lies distinctly above the  $S_1$  state. The simultaneous torsion and elongation of the C=N bond is the most favorable geometrical variation studied for the first singlet excited state giving rise to the pair of very close lying singlet states  $S_1$  and  $S_0$ . The lowest singlet state  $S_0$  for the  $90^\circ$  twisted C=N bond receives the largest contribution from the ionic structure with the charge transfer to the N—H group while  $S_1$  is of covalent diradical nature. Between this pair of singlet states lies the lowest triplet state with localized excitation in the C=N bond. Other considered singlet and triplet states do not approach these lowest states during the twist motion of the C=N bond. The relaxation of the C=N bond in formaldimine leads to completely analogous results. A comparison with torsion of the C=C bond in ethylene and butadiene is made. Photochemical implications are proposed.

## I. Introduction

Rotations around double and single bonds of polyenes and their analogues (Schiff base polyenes) have been the topic of several theoretical studies<sup>1-9</sup> because of their importance in photoisomerization. The idea that the first step in vision might proceed via isomerization was introduced in the literature a long time ago (for recent review, see ref 10). In connection with the possible mechanism of vision,<sup>11</sup> attention has been paid also to the singlet excited electronic states of the twisted species which exhibit large charge separation (sudden polarization effect),<sup>12-14</sup> although other kinds of mechanisms have been proposed.<sup>7,8,10</sup> Nevertheless, very little is known about the photoisomerization mechanism of imines.<sup>15</sup>

Therefore, the study of geometrical relaxation in several low-lying singlet and triplet states of the free unprotonated Schiff base is of great interest. Determination of corresponding energy surfaces for torsion and elongation of different C=C, C=N, and C—C bonds, as well as the characterization of the changes in electronic structure of different states along the geometrical variations, represent only a starting point in the chain of effects which require careful consideration in order to gain some understanding of the mentioned complex problems.

In this paper the geometrical relaxation in the four lowest singlet and three lowest triplet states of allylideneimine ( $\text{CH}_2=\text{CHC}(\text{H})=\text{NH}$ ) has been studied, employing ab initio large-scale CI methods. The properties, e.g. dipole moments, of various states for torsion of different bonds have been determined. Characterization of the important features of the electronic wave functions in terms of covalent and ionic VB-like structures for geometrical relaxation of different bonds and their comparison with the corresponding wave functions of terminally twisted butadiene<sup>16</sup> and of twisted formaldimine ( $\text{CH}_2=\text{NH}$ ) make possible some conjectures on the corresponding states for larger systems.

## II. Method

Multireference double CI treatments<sup>17</sup> of the same quality as in the case of butadiene<sup>16</sup> have been employed for the simultaneous description of several singlet and triplet states for differently relaxed geometries. Because of the acceptor nature of the nitrogen atom, the twisting and elongation of the double bonds produce

Scheme I

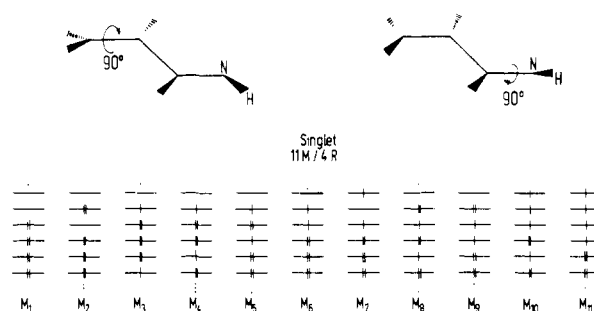

Scheme II

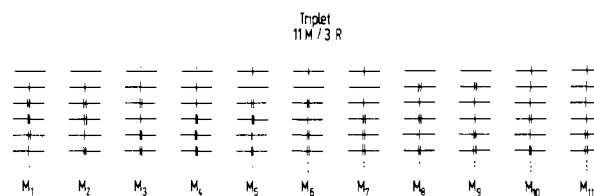

a biradical with a large electronegativity differences between two radical centers. The avoided crossings between different states,

- (1) R. Hoffmann, *Tetrahedron*, **22**, 521 (1966).
- (2) N. C. Baird and R. M. West, *J. Am. Chem. Soc.*, **93**, 4427 (1971).
- (3) J. Michl, *Mol. Photochem.*, **4**, 243, 257, 287 (1972); *Top. Curr. Chem.*, **46**, 1 (1974).
- (4) J. Langlet and J. Malrieu, *Theor. Chim. Acta*, **33**, 307 (1974).
- (5) V. Bonačić-Koutecký and S. Ishimaru, *J. Am. Chem. Soc.*, **99**, 8134 (1977).
- (6) I. Ohmine and K. Morokuma, *J. Chem. Phys.*, **73**, 1907 (1980).
- (7) (a) K. Schulten and P. M. Tavan, *Nature (London)*, **85**, 272 (1978); (b) C. Orlandi and K. Schulten, *Chem. Phys. Lett.*, **64**, 370 (1979).
- (8) (a) A. Warshel, *Nature (London)*, **260**, 679 (1976); (b) R. M. Weiss and A. Warshel, *J. Am. Chem. Soc.*, **101**, 6131 (1979).
- (9) A. C. Lasage, R. J. Aerni, and M. Karplus, *J. Chem. Phys.*, **73**, 5230 (1980).
- (10) P. Dupuis, F. I. Hárosi, C. Sándorfy, J. M. Leclercq, and D. Vocelle, *Rev. Can. Biol.*, **39**, 247 (1980).
- (11) L. Salem and P. Bruckmann, *Nature (London)*, **258**, 526 (1975).
- (12) V. Bonačić-Koutecký, P. Bruckmann, P. Hiberty, J. Koutecký, C. Leforestier, and L. Salem, *Angew. Chem., Int. Ed. Engl.*, **14**, 575 (1975).

† Permanent Address: Università di Pisa, Istituto di Chimica Fisica, I-56100 Pisa, Italy.

Scheme III

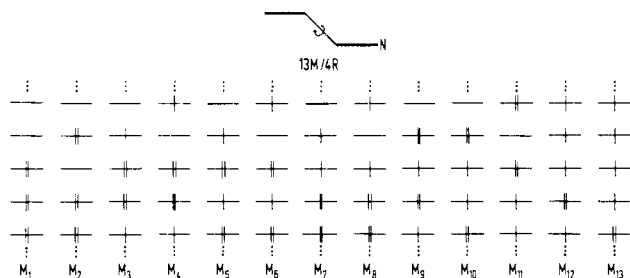

Scheme IV

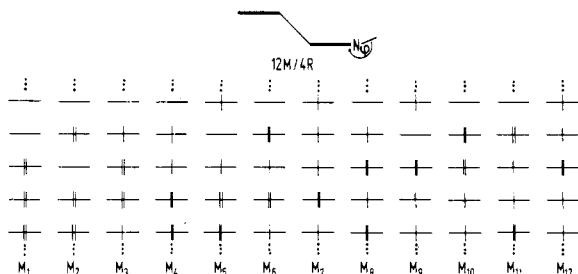

which arise as the consequence of a geometrical relaxation, are strongly avoided so that the simultaneous description of the singlet states of covalent, ionic, or mixed nature does not essentially depend on the details of the CI procedure as in the case of butadiene. In other words, if the reference CI spaces is properly chosen and the one-electron basis employed for building up CI spaces does not favor one state over the other, the shapes and relative positions of variational energy surfaces are parallel to those obtained employing the averaged extrapolation technique<sup>16</sup> or Siegbahn's full CI estimate<sup>18</sup> for energies. The variational energies have been obtained by diagonalization of the CI spaces containing up to 10 000 configurations which are selected from the "full" MRD CI spaces ( $T = 0$ ). Their dimensions range from 300 000 to 360 000 for four singlet states of allylideneimine, and they are even larger in the case of the considered triplet states (600 000).

The reference spaces for the four lowest valence singlet states for torsion around C=C and C=N bonds, i.e., in the twist intervals  $\theta_1 = \{0, 180^\circ\}$  and  $\theta_3 = \{0, 180^\circ\}$ , respectively, consist of 11 reference configurations differing in occupation numbers of 6 MO's (cf. Scheme I).

In addition to two  $\pi$  and two  $\pi^*$  orbitals, the MO which is primarily of nitrogen lone pair nature plays an important role. For the same twist motions the configurations building up the reference spaces for three considered triplet states are given in Scheme II.

For other geometrical variations studied as for the twist around the single C-C bond in the interval  $\theta_2 = (0, 180^\circ)$  and for the in-plane flipping of the hydrogen atom attached to the nitrogen in the interval  $\theta_1 = (120, 240^\circ)$ , the configurations spanning the reference CI spaces for four singlet states are given in Schemes III and IV, respectively.

As the main emphasis has been put on the relaxation effects producing biradicals, the triplet SCF MO's are the most convenient choice for the one-electron functions in the CI treatments (T-

Scheme V

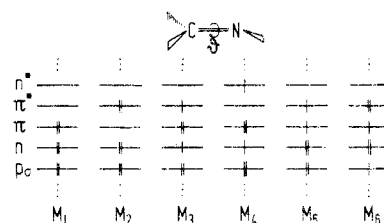

MO-CI) as it has been already discussed in previous related papers.<sup>14,16,19,20</sup> In addition, we have employed closed-shell SCF MO's to build up the CI spaces (S-MO-CI) for some interesting parts of the twisting intervals in order to find out to what extent the large-scale (but not the full) CI is capable of in overcoming the deficiency of the one-electron functions. Also a careful examination has been made concerning the influence of exclusion of a certain number of occupied MO's and their virtual counterparts from the CI treatments on the qualitative and quantitative features of the wave functions. Besides the four lowest occupied MO's which primarily contain 1s AO orbitals, an additional four occupied MO's can be excluded from the CI treatments without causing any substantial changes in the shapes of energy surfaces or the ordering of states because they are mainly involved in the C-H bonding. Therefore, the eight lowest occupied MO's and four highest virtual counterparts have been excluded from the CI treatments. The explicit consideration of correlation for only 14 electrons and not for 30 electrons makes it possible to use a lower value for the energy selection threshold  $T$  so that the size of the CI space, for which it is practicable to carry out diagonalization, represents the larger part of the full MRD CI space. Finally we have employed the 4-31G AO basis set<sup>21</sup> as in the study of relaxation effects in butadiene.<sup>16</sup> The emphasis has not been put on determination of the excitation energies for the planar allylideneimine. Nevertheless, low-lying valence excited states at the planar geometry have been calculated in order to correlate these states with the low-lying excited states for relaxed geometries. The study concerning the influence of different AO basis sets on properties of excited states has been carried out for the twist around the C=N bond of formaldehyde. In this case a comparison between the results obtained employing the 4-31G, 6-311G,\*\*<sup>22</sup> or double- $\zeta$  basis set augmented by polarization functions<sup>23</sup> shows that the overall picture of the energy surfaces remains unchanged. The CI treatments with six reference configurations for four singlet states and three triplet states of formaldehyde (6M/4R and 6M/3R) have been employed. These configurations differ from each other in the occupation numbers of five MO's which can be characterized as  $p_\sigma$ ,  $n$  lone pair at nitrogen,  $\pi$ ,  $\pi^*$ , and  $(n-\pi)^*$ . For the singlet states the main configurations are given in Scheme V. The two closed-shell configurations  $M_1$  and  $M_2$  are replaced by one doubly excited configuration  $(n \rightarrow \pi^*)(\pi \rightarrow \pi^*)$ , and one singly excited configuration  $(\pi \rightarrow n^*)$  in the case of triplet states. Only two core MO's and their virtual counterparts are excluded from the CI treatment. The dimension of the full MRD-CI space for the four singlet states and three triplet states with 4-31G basis is  $\sim 25\,492$  and  $45\,030$ , respectively. Using the energy selection threshold  $T = 15 \mu\text{hartree}$ , up to  $\sim 7000$  configurations are selected. If 6-311G\*\* is employed, the total number of spin-adapted functions for singlet states is 299 103 from which up to  $\sim 6000$  are selected, setting the energy selection threshold at  $T = 40 \mu\text{hartree}$ . The energy surfaces obtained by the averaged ex-

(13) L. Salem, *Acc. Chem. Res.*, **12**, 87 (1979), and references therein.

(14) V. Bonačić-Koutecký, L. Pogliani, M. Persico, and J. Koutecký, *Tetrahedron*, **38**, 741 (1982), and references therein.

(15) G. Wettermark, "The Chemistry of the Carbon-Nitrogen Double Bond", Patai, Ed., Interscience, New York, 1970, p 565.

(16) (a) V. Bonačić-Koutecký, M. Persico, D. Döhnert, and A. Sevin, *J. Am. Chem. Soc.*, **104**, 6900 (1982); (b) V. Bonačić-Koutecký and M. Persico, *Int. J. Quantum Chem.*, **23**, 517 (1983); (c) Bonačić-Koutecký, *Appl. Pure Chem.*, **55** (2), 213 (1983).

(17) (a) R. J. Buenker and S. D. Peyerimhoff, *Theor. Chim. Acta*, **35**, 33 (1974); (b) R. J. Buenker, S. D. Peyerimhoff, and W. Butscher, *Mol. Phys.*, **35**, 771 (1978).

(18) P. E. M. Siegbahn, *Chem. Phys. Lett.*, **55**, 386 (1978).

(19) V. Bonačić-Koutecký, R. J. Buenker, and S. D. Peyerimhoff, *J. Am. Chem. Soc.*, **101**, 5917 (1979).

(20) R. J. Buenker, V. Bonačić-Koutecký, and L. Pogliani, *J. Chem. Phys.*, **73**, 1836 (1980).

(21) R. Ditchfield, W. J. Hehre, and J. A. Pople, *J. Chem. Phys.*, **54**, 724 (1971).

(22) R. Krishan, J. S. Binkley, R. Seeger, and J. A. Pople, *J. Chem. Phys.*, **72**, 650 (1980).

(23) T. H. Dunning, Jr., and P. J. Hay in "Methods of Electronic Structure Theory", H. F. Schaefer III, Ed., Plenum Press, New York, 1977, pp 1-127.

Scheme VI

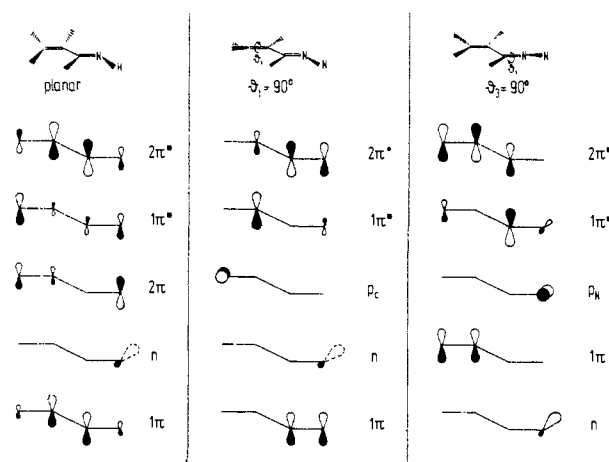

trapolation technique described elsewhere<sup>16a</sup> (extrapolating toward  $T = 0$ ) are parallel to the variational energy surfaces. The T-MO-CI and S-MO-CI treatments have been compared in the whole twist interval.

### III. Geometrical Relaxation in the C=C and C=N Bonds in Allylideneimine

The important MO's having different occupation numbers in the reference configurations for planar and the 90° terminally twisted allylideneimine are given in Scheme VI. For the planar geometry the first valence excited singlet state  $S_1$  is of pronounced ( $n \rightarrow \pi^*$ ) nature with the leading  $M_5$  configuration from Scheme I, while the other two considered singlet excited states  $S_2$  and  $S_3$  are analogous to the  $2^1A_g$  and  $1^1B_u$  states of butadiene (cf. ref 16a and references therein). The three leading configurations, i.e., one doubly excited  $M_2$ , ( $2\pi \rightarrow 1\pi^*$ )( $2\pi \rightarrow 1\pi^*$ ), and two complementary singly excited ones  $M_4$  and  $M_7$ , ( $1\pi \rightarrow 1\pi^*$ ) and ( $2\pi \rightarrow 2\pi^*$ ) (cf. Scheme Ia), enter the wave function of the  $S_2$  state with almost equal weights. The  $S_3$  state contains predominantly the singly excited configuration  $M_6$ , ( $2\pi \rightarrow 1\pi^*$ ) (cf. Schemes I and VI). The lowest two triplet states  $T_1$  and  $T_2$  are of ( $2\pi \rightarrow 1\pi^*$ ) and ( $n \rightarrow 1\pi^*$ ) nature, while the wave function of the  $T_3$  state contains predominantly the  $M_2$ ,  $M_7$ , and  $M_{10}$  configurations from Scheme II.

For the terminally twisted geometries the important MO's from Scheme VI are localized in two molecular parts separated by the twisted C=C or C=N bond, i.e., in the CCN triad + methylene for  $\theta_1 = 90^\circ$  and in the allylic triad + NH group for  $\theta_3 = 90^\circ$ . Therefore, it is easy to analyze the contributions of the leading configurations to the correlated wave functions in terms of localized VB-like structures (cf. also ref 16). They can be grouped in five classes.

I. D (D'): "the CCN (or allylic) ground state + methylenic (or NH)" structure for the 90° twisted C=C (or C=N) bond,

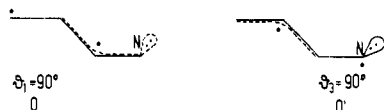

assigned to the configuration with CCN (or allylic) localized MO's occupied as in the ground state of the CCN system (or of allyl) and with singly occupied methylene (or NH) localized MO.

II. C (C'): "excited CCN (or allylic) triad + methylenic (or NH)" structure for the 90° twisted C=C (or C=N) bond, as-

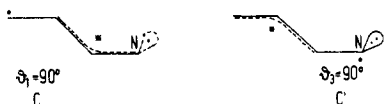

signed to all configurations with CCN (or allylic) localized MO's occupied as in the excited states of the CCN system (or of allyl)

Scheme VII

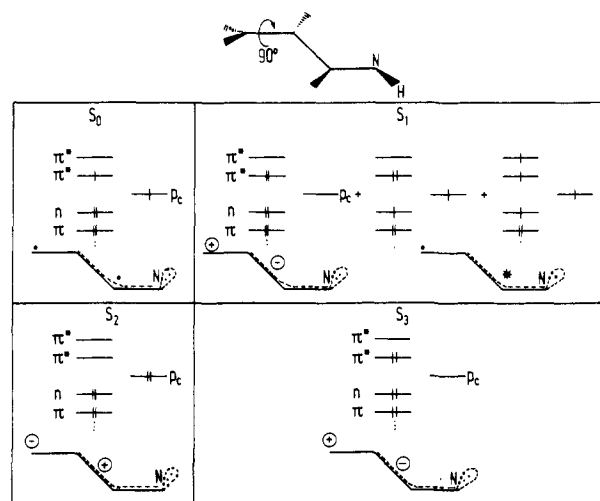

and with singly occupied methylene (or NH) localized MO.

III. N: "localized  $n \rightarrow p_N$  excitation within the NH group + ground state allyl" for the 90° twisted C=N bond.

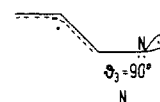

IV.  $Z_1$  ( $Z_1'$ ): "charge transfer to the methylene (or NH)" for the 90° twisted C=C (or C=N) bond, assigned to the confi-

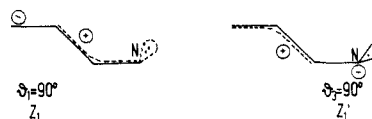

guration with one (or two) doubly occupied methylene (or NH) localized MO's.

V.  $Z_2$  ( $Z_2'$ ): "charge transfer to the CCN (or allyl)" structure for the 90° twisted C=C (or C=N) bond, assigned to the con-

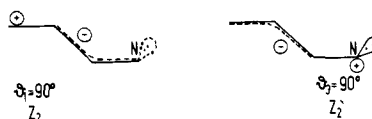

figuration with three (or two) doubly occupied localized CCN (or allylic) MO's.

The D, C, and N VB-like structures are covalent, while  $Z_1$  and  $Z_2$  are of ionic nature. According to their contribution to the correlated wave function, the characterization of covalent, ionic, or mixed nature of the excited states can be made.

For the 90° twisted C=C bond, the assignment of the four VB-like structures to the leading configurations in the expansion of the correlated wave functions for the four singlet states, obtained employing 11M/4R,  $T = 15 \mu\text{hartree}$  CI treatment with triplet MO's (T-MO-CI) described in section II, has been made in Scheme VII. The lowest singlet state  $S_0$  is a biradical covalent state (D). The  $S_1$  state contains a mixture of the ionic structure  $Z_1$  and the "excited" covalent structure C (with larger weight). In comparison with butadiene the mixed ionic and covalent nature of  $S_1$  is due to the asymmetry introduced through nitrogen atom substitution. The  $S_2$  and  $S_3$  states are pronounced polar states characterized by  $Z_1$  and  $Z_2$  structures.

The calculated energy surfaces for the four singlet states and three triplet states obtained from 11M/4R and 11M/3R,  $T = 15 \mu\text{hartree}$  CI treatments, described in section II for the torsion and elongation of the C=C bond, are given in Figure 1. Triplet MO's are employed to build up both triplet and singlet CI spaces. The twist and elongation of the C=C bond yields a barrier of  $\sim 60$  kcal/mol in the singlet ground state  $S_0$ . This geometrical

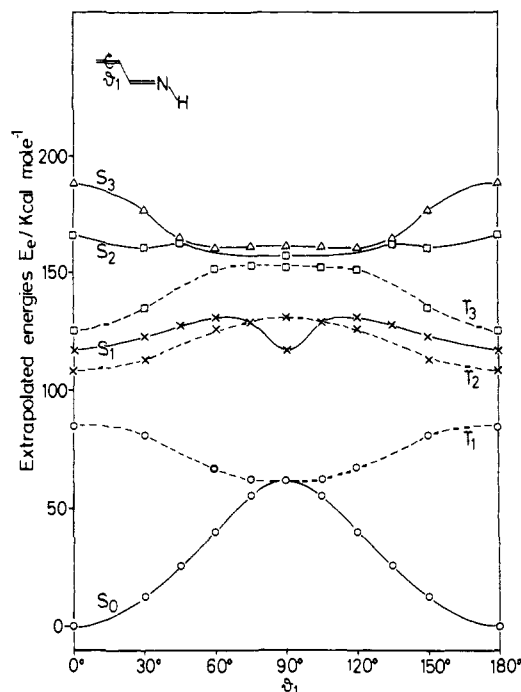
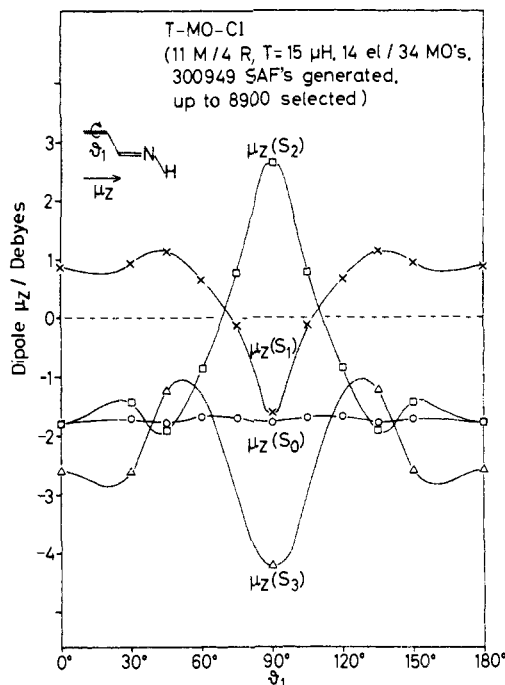

**Figure 1.** Averaged extrapolated energies of the four singlet states  $S_0$ ,  $S_1$ ,  $S_2$ ,  $S_3$  and the three triplet states  $T_1$ ,  $T_2$ ,  $T_3$  of allylideneimine as a function of the twist  $\theta_1$  and the elongation of the C=C bond. The twisted bond has been elongated from 1.345 Å for  $\theta_1 = 0^\circ$  to 1.416 Å for  $\theta_1 = 90^\circ$ . The length of the C=C bond for the given twist angle  $\theta_1$  has been determined according to:  $l(\theta_1) = \sin^2 \theta_1 l(90^\circ) + \cos^2 \theta_1 l(0^\circ)$ . For singlet and triplet states, the extrapolation has been carried out for the variational energies obtained from 11M/4R and 11M/3R CI treatments respectively with the energy selection threshold  $T = 15 \mu\text{hartree}$  (for 11 reference configurations cf. Schemes I and II). Eight lowest occupied MO's and four highest virtual MO's are not included in the CI. For the singlet states from 300 949 spin-adapted functions up to 8900 are selected. For the triplet states from 574 402 spin-adapted functions up to 6315 are selected. Triplet SCF MO's are employed in the CI treatments (T-MO-CI) for singlet and triplet states. The 4-31G AO basis is used.

change is energetically favorable for the lowest triplet  $T_1$  which at  $\theta_1 = 90^\circ$  lies only by 0.05 kcal/mol lower than the  $S_0$  covalent diradical state characterized by structure D. At  $\theta_1 = 90^\circ$  the triplet excitation is localized in the twisted C=C bond so that the  $T_1$  can be also characterized through the covalent structure D. The twist around the C=C bond is unfavorable for  $n \rightarrow \pi^*$  singlet and triplet states. Nevertheless, as the  $S_1$  ( $n \rightarrow \pi^*$ ) state gains the contribution of the covalent excited structure C and of the charge-transfer structure  $Z_2$  for twist angles around  $\theta_1 = 90^\circ$ , the energy is lowered so that the barrier to rotation is only about 14 kcal/mol. The energies of  $S_1$  at planar and at  $\theta_1 = 90^\circ$  twisted geometries are equal, lying 117 kcal/mol above the ground state  $S_0$  of planar allylideneimine. Two other considered valence singlet states lie very close to each other in the twist interval  $\theta_1 = \{45-135^\circ\}$ . The acceptor effects of methylene and the nitrogen atom compete so strongly that both zwitterionic polar states are almost of the same energy but lie high above the first singlet excited state  $S_1$ .

The described changes in the nature of the wave functions of the valence excited singlet state as consequence of the twist around the C=C bond is mirrored in the changes of the dipole moment component  $\mu_z$  as shown in Figure 2. As expected, for the planar geometry the  $\mu_z$  of the  $n \rightarrow \pi^*$  state  $S_1$  has opposite sign to the  $\mu_z$  of the ground-state  $S_0$ . As soon as  $S_1$  loses its  $n \rightarrow \pi^*$  character,  $\mu_z$  becomes negative and at  $\theta_1 = 90^\circ$  both states  $S_0$  and  $S_1$  have almost equal dipole moments. The covalent contribution prevails in the  $S_1$  state. Very large positive and negative values of  $\mu_z$  for  $S_2$  and  $S_3$  at  $\theta_1 = 90^\circ$  indicate an extra charge at methylene and in the CCN triad, respectively.

Comparing the energies of the excited states for planar and the  $90^\circ$  twisted geometries around the C=C bond with those of



**Figure 2.** The  $\mu_z(S_i)$  ( $i = 0, 1, 2, 3$ ) components of the dipole moments of the  $S_0$ ,  $S_1$ ,  $S_2$ , and  $S_3$  states of allylideneimine as a function of the twist  $\theta_1$  and the elongation of the C=C bond for the same variational treatments as in Figure 1.

#### Scheme VIII

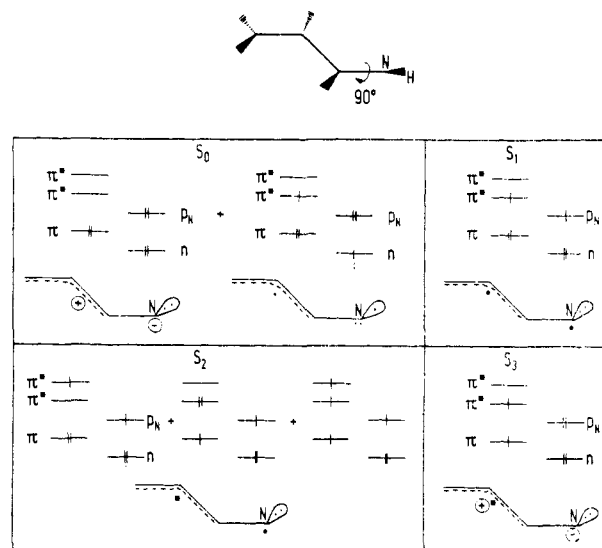

butadiene, the striking difference is that the  $S_1$  state of allylideneimine lies energetically closer to the ground-state  $S_0$  than in the case of butadiene (cf. ref 16). For the planar geometry the  $n \rightarrow \pi^*$  state is substantially below (by  $\sim 50$  kcal/mol) the analogues of the  $2^1A_g$  and  $1^1B_u$  states. At the  $\theta_1 = 90^\circ$  twist,  $S_1$ , which is of mixed covalent and ionic nature, lies 48.1 kcal/mol above  $S_0$  while in the case of  $90^\circ$  terminally twisted butadiene the  $S_1$  state is of polar zwitterionic nature and lies 73.1 kcal/mol above the  $S_0$ . (The full CI estimated energies are compared.)

In comparison with the geometrical relaxation of the C=C bond, torsion and elongation of the C=N bond in allylideneimine give rise to completely different features of the energy surfaces as shown in Figure 3. This geometrical relaxation is extremely favorable for the first singlet valence excited state  $S_1$  which undergoes an avoided crossing with the lowest singlet state  $S_0$  in the neighborhood of  $\theta_3 = 90^\circ$ . Therefore, at  $\theta_3 = 90^\circ$  the energy gap between these two states is only  $\sim 10$  kcal/mol. The configuration assigned to the ionic structure  $Z_1'$  dominates the expansion of the

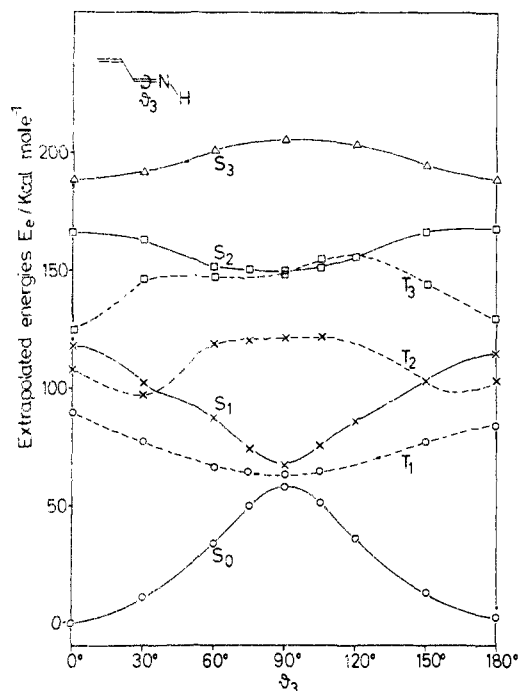

**Figure 3.** Averaged extrapolated energies of the four singlet states  $S_0$ ,  $S_1$ ,  $S_2$ ,  $S_3$  and the three triplet states  $T_1$ ,  $T_2$ ,  $T_3$  of allylideneimine as a function of the twist  $\theta_3$  and elongation of the C=N bond for the same treatments as in Figure 1. The twisted bond has been elongated from 1.30 Å for  $\theta_3 = 0^\circ$  to 1.37 Å for  $\theta_3 = 90^\circ$ . The length of the C=N bond for the given twist angle  $\theta_3$  has been determined according to:  $l(\theta_3) = \sin^2 \theta_3 l(90^\circ) + \cos^2 \theta_3 l(0^\circ)$ .

$S_0$  wave function, although the structure N representing localized  $n \rightarrow p_N$  excitation contributes also moderately to  $S_0$  as shown in Scheme VIII.  $S_1$  can be characterized by the covalent diradical structure D'. The barrier to rotation in the ground state is  $\sim 5$  kcal/mol lower than in the case of the torsion around the C=C bond. The lowest triplet state  $T_1$  lies inbetween  $S_0$  and  $S_1$  (cf. Figure 3), and the corresponding wave function can be characterized by the covalent diradical structure D'. This indicates that the excitation in  $T_1$  is localized in the C=N bond. The energy surfaces of other two valence excited states lie substantially above the lowest two states  $S_0$  and  $S_1$  in the whole twist interval (cf. Figure 3). At  $90^\circ$  twist,  $S_2$  is of excited covalent nature (cf. Scheme VIII). It is worth pointing out that the polar zwitterionic state with charge transfer to the allylic triad characterized by the VB-like structure Z' does not lie among the four lowest singlet states. The twist around the C=N is energetically strongly unfavorable for the ionic structure with the extra charge in the allylic triad because of the acceptor nature of the nitrogen atom. Consequently, the  $z$  component of the dipole moment  $\mu_z$  for all four singlet states has negative values in most part of the twist interval  $\theta_3$  as shown in Figure 4. At  $\theta_3 = 90^\circ$  the two pronounced covalent states  $S_1$  and  $S_2$  have smaller absolute values of dipole moment  $\mu_z$  than the lowest singlet state  $S_0$ .

In order to find out how the different one-electron functions employed in the CI treatments influence the relative energies and values of the dipole moment of the excited states, the closed-shell singlet SCF MO's (S-MO-CI) have been employed for planar and for the  $90^\circ$  terminally twisted geometries ( $\theta_1$  or  $\theta_3$ ). In general, the states which contain large contributions from the closed-shell H-F configuration in the CI wave function are strongly favored in the S-MO-CI treatments, while the states with large contributions from the doubly excited configurations with doubly occupied  $\pi^*$  MO are very poorly described. Consequently, for the planar geometry the excitation energies for the  $n \rightarrow \pi^*$  ( $S_1$ ) state are almost equal in both treatments employing triplet and singlet MO's (T-MO-CI and S-MO-CI). The " $2^1A_g$ " state ( $S_2$ ) is poorly described in S-MO-CI because of the contribution of the doubly excited configuration  $M_2$  from Scheme I. Therefore, the CI with

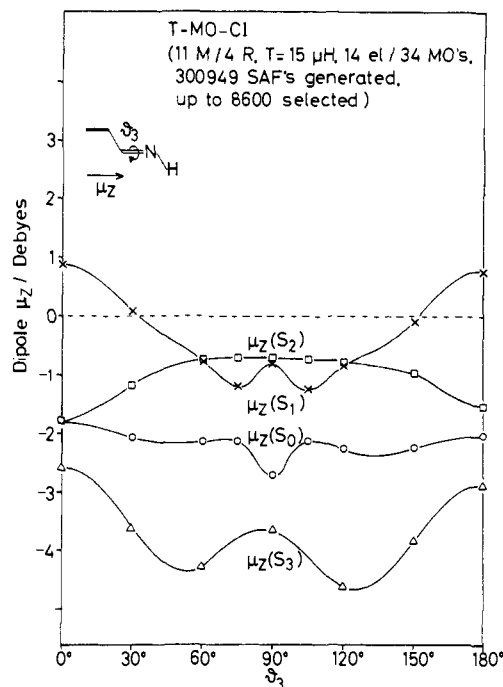

**Figure 4.** The  $\mu_z(S_i)$  ( $i = 0, 1, 2, 3$ ) components of the dipole moments of the  $S_0$ ,  $S_1$ ,  $S_2$ , and  $S_3$  states of allylideneimine as a function of the twist  $\theta_3$  and the elongation of the C=N bond for the same variational treatments as in Figure 3.

this choice of one-electron functions yields a smaller energy gap between " $2^1A_g$ " ( $S_2$ ) and " $1^1B_u$ " ( $S_3$ ) states than the T-MO-CI treatment. For  $90^\circ$  twist around the C=N bond the  $S_0$  state with large contribution of the HF closed-shell configuration has lower energy if the S-MO-CI instead of the T-MO-CI treatment is employed so that the energy gap  $S_0$ - $S_1$  is larger in the former case ( $\sim 19$  instead of  $\sim 10$  kcal/mol). For  $90^\circ$  twist around the C=C bond the  $S_1$  state which contains the configuration with doubly occupied  $\pi^*$  MO ( $M_2$  from Scheme I) is difficult to obtain in the S-MO-CI treatment. In spite of the quantitative differences, the ordering of states and the characteristics of the wave functions remain the same in both types of treatments. The values of dipole moments are neither substantially influenced by the choice of the one-electron basis in the CI treatments.

Simultaneous twist around C=C and C=N bonds gives rise to a large barrier in the singlet ground state (87.4 kcal/mol). The energy lowering of the  $S_1$  state is not so large as in the case of the twist around the C=N bond, but there is also no barrier to rotation as in the twist around the C=C bond. In addition the  $S_1$  energies at planar and at  $\theta_1 = \theta_3 = 90^\circ$  twisted geometries are almost equal, indicating a shallow minimum on the  $S_1$  energy surface in the twist interval  $\theta_1 = \theta_3 = \{[30, 60^\circ]\}$ .

The twist around the C=N bond is by far the most favorable geometrical relaxation in the singlet excited state  $S_1$ .

#### IV. Planar Inversion of the Hydrogen Atom in Allylideneimine

The energy surfaces of the four singlet states for in-plane flipping of the hydrogen atom obtained employing the T-MO-CI treatment (12M/4R,  $T = 15 \mu\text{hartree}$ ) described in section II (cf. Scheme V) are given in Figure 5. The barrier to planar inversion in the ground state is substantially smaller (30.6 kcal/mol)<sup>24-26</sup>

(24) The experimental values for barriers to planar inversion in alkyl-substituted imines range from 25 to 27 kcal/mol;<sup>25</sup> calculated barriers to planar inversion for formaldehyde range from 26 to 28 kcal/mol.<sup>26</sup>

(25) (a) G. W. Koepl, D. S. Sagatys, G. S. Krishnamurthy, and S. I. Miller, *J. Am. Chem. Soc.*, **89**, 3396 (1967); (b) D. Y. Curtin, E. J. Grubbs, and C. G. McCarthy, *ibid.*, **88**, 2275 (1966); (c) D. Wurmb-Gerlich, F. Vogtle, A. Mannschreck, and H. A. Staab, *Justus Liebigs Ann. Chem.*, **708**, 36 (1967).

(26) (a) J. M. Lehn and B. Munsch, *Theor. Chim. Acta*, **12**, 91 (1968); (b) J. M. Lehn, B. Munsch, and P. M. Millié, *ibid.*, **16**, 351 (1970); (c) R. Macaulay, L. A. Burnelle, and C. Sandorfy, *ibid.*, **29**, 1 (1973).

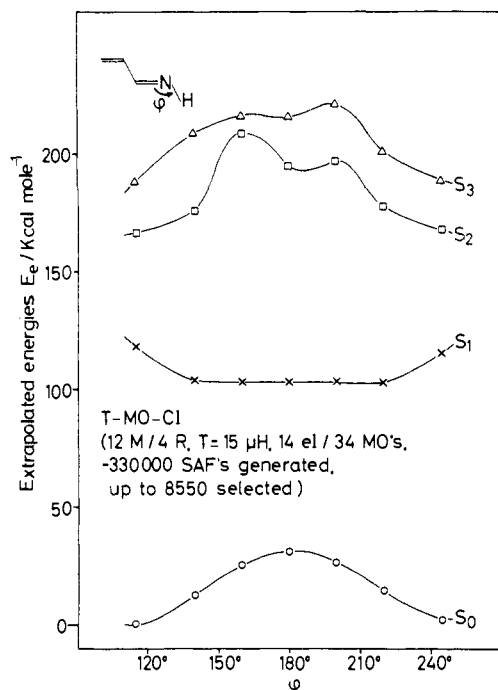

**Figure 5.** Averaged extrapolated energies of the four singlet states  $S_0$ ,  $S_1$ ,  $S_2$ , and  $S_3$  of allylideneimine as a function of the hydrogen in-plane flipping angle  $\phi$  obtained from the 12M/4R CI treatments (cf. Scheme IV for the choice of main configurations) with the energy selection threshold  $T = 15 \mu$ hartree (eight lowest occupied and four highest virtual MO's are not included in CI). From 330 000 spin-adapted functions up to 8550 are selected. The 4-31G AO basis is used and the triplet SCF MO's are employed in the CI treatments (T-MO-CI).

**Table I.** Dipole Moments of Four Singlet States for Different Flipping Angles  $\phi_1$  of Hydrogen Atom Attached to Nitrogen (in Debyes)

$\phi_1$	$\mu_z(S_0)$	$\mu_z(S_1)$	$\mu_z(S_2)$	$\mu_z(S_3)$
115	-1.795	0.851	-1.807	-2.598
160	-0.330	1.879	0.183	-1.182
180	-0.060	2.048	0.197	-0.899
200	-0.422	1.821	-0.057	-1.269
220	-1.162	1.416	-0.760	-1.955
245	-2.049	0.767	-1.540	-1.136

than the barriers to individual rotation around the C=C or C=N bonds. The first singlet excited state is shallow. After a decrease in energy by  $\sim 15$  kcal/mol, the energies are almost constant in the flipping interval  $\phi_1 = 140\text{--}220^\circ$ . The nature of the leading features of the wave functions of  $S_0$  and  $S_1$  remains unchanged during this geometrical variation. The  $S_0$  contains the largest contribution from the closed-shell configuration  $M_1$  (from Scheme V), and the  $S_1$  is of  $n\text{--}\pi^*$  nature with a large contribution from  $M_8$  (cf. Scheme V). The dipole moment component  $\mu_z$  for  $S_0$  and  $S_1$  given in Table I changes with the flipping angle  $\phi_1$  because of changed positions of the lone pair and the p orbital of the nitrogen atom.

Comparing the shapes of energy surfaces for first singlet excited states which result from the torsion and elongation of the C=N bond with those resulting from the hydrogen flipping in the plane, it is more likely that after absorption into the  $n \rightarrow \pi^*$  state, the rapid relaxation through torsion to  $90^\circ$  will occur, and rapid return to the ground state will proceed followed by downhill relaxation in both directions toward smaller and larger angles than the  $90^\circ$  twist.

#### V. Twist around the Single C-C Bond in Allylideneimine

As expected, the torsion around the single bond gives rise to a lower barrier in the ground state  $S_0$  ( $\sim 10$  kcal/mol) than in the first excited state ( $\sim 30$  kcal/mol) as can be seen from Figure 6. At  $\theta_2 = 90^\circ$  the five important MO's from which the reference

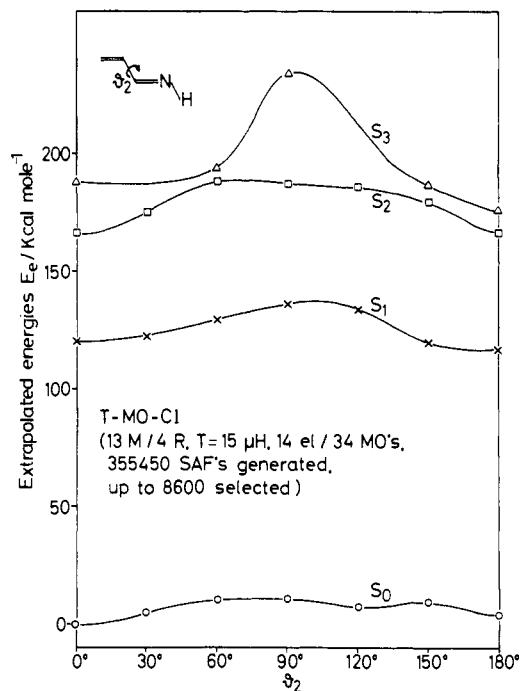

**Figure 6.** Averaged extrapolated energies of the four singlet states  $S_0$ ,  $S_1$ ,  $S_2$ , and  $S_3$  of allylideneimine as a function of the twist  $\theta_2$  around the single C-C bond (1.47 Å) obtained from the 13M/4R CI treatments (cf. Scheme III for the choice of main configuration) with  $T = 15 \mu$ hartree (eight lowest occupied and four highest virtual MO's are not included in CI). From 355 450 spin-adapted functions up to 8600 are selected. The 4-31G AO basis set and triplet SCF MO's are employed in the CI treatments (T-MO-CI).

**Table II.** Energies of Four Singlet States for Some Relaxed Geometries with Respect to the Ground State of Planar Allylideneimine (in kcal/mol)

$\theta_1^a$	$\theta_2^a$	$\theta_3^a$	$S_0$	$S_1$	$S_2$	$S_3$
0	0	0	0	117.0	166.0	188.0
90	0	0	62.1	117.0	161.2	177.3
0	90	0	10.9	136.3	187.1	234.8
30	30	0	17.5	123.8	164.1	181.3
90	30	0	67.5	135.9	151.7	168.0
90	90	0	77.1	154.1	187.0	190.6
0	0	90	57.4	67.0	149.7	205.0
0	30	30	14.3	126.0	165.5	189.1
0	30	90	61.2	70.0	147.7	
0	90	90	67.9	83.5	183.0	196.4

<sup>a</sup>  $\theta_1$ ,  $\theta_2$ , and  $\theta_3$  are twist angles (deg) around the C=C, C-C, and C=N bond, respectively.

space is built up (cf. Scheme IV) are localized in two parts attached to the twisted bond. HOMO and LUMO are bonding, with the antibonding  $p_z$  orbitals localized in the C=C part. The first and the second MO's below the HOMO are of lone-pair nitrogen nature and  $\pi$ -bonding character localized in the C=N part, respectively. The fifth important MO is the  $\pi^*$ -antibonding counterpart of the latter. The closed-shell configuration  $M_1$  (cf. Scheme IV) dominates the  $S_0$  wave function, and the singly excited configuration  $M_6$  ( $n \rightarrow \pi^*$ ) (cf. Scheme IV) is the leading configuration in the  $S_1$  state. Moreover, the energy difference  $S_0$ - $S_1$  at the  $90^\circ$  twisted single C-C bond is very large ( $\sim 125$  kcal/mol). The torsion around the single C-C bond is by far the most unfavorable geometrical relaxation for the first singlet excited-state  $S_1$ .

Simultaneous twist around the single C-C bond and one of the double bonds C=C or C=N is energetically less favorable for the singlet states than the geometrical relaxation of the individual double bonds. Comparison of energies of the four singlet states for different relaxed geometries is given in Table II. Simultaneous torsion around C=N and the C-C single bonds is energetically favorable for the first singlet excited-state  $S_1$ . The

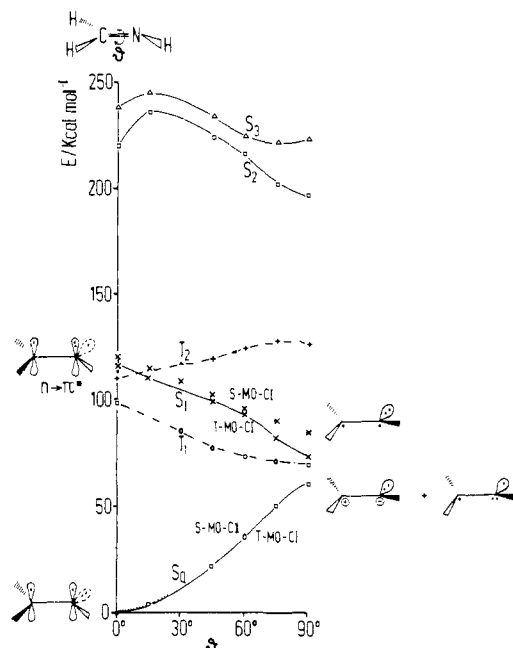

**Figure 7.** Averaged extrapolated energies of the four singlet states  $S_0$ ,  $S_1$ ,  $S_2$ ,  $S_3$  and two triplet states  $T_1$ ,  $T_2$  of formaldimine as a function of the twist  $\theta$  and the elongation of the  $C=N$  bond. The twisted bond has been elongated from 1.30 to 1.37 Å (cf. Figure 3). For singlet and triplet states the extrapolation has been carried out for the variational energies obtained from the 6M/4R selection threshold  $T = 15 \mu\text{hartree}$  (for six reference configurations, compare scheme V and section II). Two lowest occupied MO's and their virtual counterparts are not included in the CI. Triplet (—) or (---) singlet SCF MO's are employed in the CI treatments (T-MO-CI or S-MO-CI). The 4-31G AO basis is used.

energy of  $S_1$  is lower by  $\sim 33.0$  kcal/mol at  $\theta_2 = \theta_3 = 90^\circ$  than at planar geometry

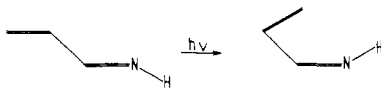

and the energy gap between  $S_0$  and  $S_1$  is 16 kcal/mol. The isomerization is energetically possible, although not highly probable. For  $\theta_1 = \theta_2 \neq 0$  the barriers in  $S_0$  and  $S_1$  are larger (cf. Table II) than for  $\theta_1 \neq 0$ . Simultaneous twist around the single and a double bonds differing in twisting angles  $\theta_1 \neq \theta_2 \neq 0$  or  $\theta_3 \neq \theta_4 \neq 0$  does not lower energies of the states more than the individual twist around a double bond.

## VI. Torsion and Elongation of the $C=N$ Bond in Formaldimine

In order to study the influence of chain elongation on the consequences of the geometrical relaxation in the  $C=N$  bond, it is interesting to compare the torsion around the  $C=N$  bond in formaldimine and in allylideneimine. The shapes of the two lowest singlet and the lowest triplet energy surfaces are strikingly similar in both cases as can be seen by comparing Figure 3 of section III with Figure 7. The features of the corresponding wave functions are also in analogy with each other. For the planar geometry, the first excited valence state  $S_1$  of formaldimine is of  $n-\pi^*$  nature (cf. Figure 7), lying  $\sim 5$  eV above the ground state (cf. ref 26c and 27). The ( $n-\pi^*$ ) transition is located at 5–5.4 eV in this type of molecule.<sup>28,29</sup> The value of the barrier to rotation in the ground state ranges from 56 to 60 kcal/mol depending on the details of the CI treatments employed (cf. ref 26). For  $90^\circ$  twist  $S_0$  receives a larger contribution from the "charge transfer

to  $NH^+$  structure than from the localized  $n-\pi^*$  as indicated in Figure 7, which is in complete analogy with the leading features of the  $S_0$  states of the  $\theta_3 = 90^\circ$  twisted allylideneimine as shown in Scheme VIII. The second singlet state  $S_1$  is of diradical nature, and the lowest triplet  $T_1$  lies inbetween  $S_0$  and  $S_1$  which undergo an avoided crossing in the twist interval  $\theta = 60-90^\circ$ . The energy gap between the two singlet states  $S_0$  and  $S_1$  of formaldimine at  $\theta = 90^\circ$  is 13.7 kcal/mol in the T-MO-CI treatment which is comparable with the energy gap of 10.1 kcal/mol for allylideneimine also in the T-MO-CI treatment.

In the case of formaldimine the whole  $S_0$  and  $S_1$  energy surfaces have been determined, also with the CI treatment employing closed-shell SCF MO' (S-MO-CI) as indicated in Figure 7. The difference between both CI treatments T-MO-CI and S-MO-CI is again most pronounced at the  $90^\circ$  twist (cf. Figure 7) for the same reasons as described in section III for allylideneimine. Overall, both energy surfaces  $S_0$  and  $S_1$  are energetically slightly better described in the T-MO-CI treatment as can be deduced from Figure 7. In addition, both singlet energy surfaces  $S_0$  and  $S_1$  have been determined in the whole twist interval employing the 6-311G\*\* AO basis set. The excitation energies  $S_0-S_1$  at planar and twisted geometries differ by 2–3 kcal/mol from those obtained employing the 4-31G AO basis set in analogous CI treatments. In other words, the details of the ab initio large-scale CI treatment do not influence the overall picture of the two lowest lying valence singlet states.

There is a striking similarity between the consequences of geometrical relaxation in the  $C=N$  bond on the electronic structure of the two lowest singlet and triplet states of formaldimine and of the diene, indicating that the effect of the additional  $C=C$  bond in allylideneimine is almost negligible.

## VII. Conclusions and Comparison with Hydrocarbon Analogues

Although, the subject of this paper is the relaxation effect in singlet and triplet states of two unprotonated Schiff bases, it is very instructive to point out the common and different features in their hydrocarbon analogues ethylene<sup>20</sup> and butadiene.<sup>16a</sup> A comparison of the changes in electronic structure of low-lying valence singlet and triplet states due to the twist around one homo- or hetero-double bond in ethylene, formaldimine, butadiene, and allylideneimine, shows the following interesting characteristic features.

(1) A barrier to rotation in the lowest singlet state  $S_0$  is smaller for the  $C=N$  double bond than for the  $C=C$  double bond of monoenes and dienes, but the planar inversion of hydrogen attached to the nitrogen atom yields an even lower barrier.

(2) The calculated excitation energies of  $n-\pi^*$  states (4.5–5 eV) in both Schiff bases are considerably lower than for the  ${}^1B_u$  or  ${}^1A_g$  state at planar geometries. In aliphatic imines<sup>30</sup> and in unconjugated imines<sup>31</sup> the  $n-\pi^*$  state with the excitation energies of  $\sim 5$  eV lies below the  $\pi-\pi^*$  state. In conjugated imines (usually with aryl groups) the  $\pi-\pi^*$  band submerges the  $n-\pi^*$  which still seems to be the lowest excited state.<sup>30</sup> Nevertheless, it seems that polar solvents lower the  $\pi-\pi^*$  transition energy.<sup>32</sup> Calculated excitation energies for the ( $\pi-\pi^*$ )<sup>1</sup> transition in allylideneimine and in formaldimine are  $\sim 7$  and  $\sim 9$  eV, respectively. In the far-ultraviolet spectra of alkyl-substituted imines there is a diffuse band centered at 7.3 eV which is likely to be first ( $\pi-\pi^*$ )<sup>1</sup> transition (cf. ref 33 and 27c). Notice that there is no special effort made to determine excitation energies in this work.

(3) Torsion around the  $C=C$  bond of ethylene gives rise to crossing between V and Z excited singlet states in Mulliken's notation which lie at the  $90^\circ$  twisted geometry, 85 kcal/mol above the singlet ground state  $S_0$  of diradical nature (cf. ref 20). In the case of the diene an additional low-lying singlet excited state comes

(27) R. Ditchfield, J. DelBene, and J. A. Pople, *J. Am. Chem. Soc.*, **94**, 703 (1972).

(28) D. A. Nelson and J. J. Worman, *Tetrahedron Lett.*, 507 (1966).

(29) R. Bonnett, *J. Chem. Soc.*, **2**, 2313 (1965).

(30) (a) A. Padwa, *Chem. Rev.*, **77**, 37 (1977); (b) A. C. Pratt, *Chem. Soc. Rev.*, **6**, 63 (1977).

(31) See R. Bonnett in ref 15.

(32) E. M. Kosower and T. S. Sorensen, *J. Org. Chem.*, **28**, 692 (1963).

(33) C. Sándorfy, ref 15, Chapter 1, p 2.

into play. The twist around one C=C double bond in butadiene brings two zwitterionic polar states and one covalent excited state close to each other so that at 90° twist all three states lie within 20 kcal/mol. The lowest of them lies 73 kcal/mol above  $S_0$  (cf. ref 16). In other words, going from monoene to diene, instead of three, four singlet states might play an important role in photochemistry. Because of two unequal radical centers in the case of butadiene the zwitterionic and covalent excited states undergo avoided crossings.

(4) Replacement of one methylene group by the NH group in monoene and in diene gives rise to a completely new situation. Because of the strong acceptor nature of the nitrogen atom, one of the ionic configurations with the charge transfer to the NH group is strongly stabilized by the twisting of the C=N bond. Moreover, even at 90° twist, in addition to the ionic contribution, excited covalent-type contributions can enter the same wave function because of asymmetry. Consequently, the state of such a mixed nature becomes the "ground state" lying below the covalent "diradical" state undergoing an avoided crossing. The ground state is fairly polar. In other words, for the twisted C=N bond in formaldimine and in allylidenimine there are only two close-lying singlet states with the energy gap between 10 and 15 kcal/mol. The difference between the qualitative features of the corresponding wave functions of the monoene and diene is in this case negligible.

(5) Torsion around the C=N bond in the allylidenimine is by far the most energetically favorable geometrical variation for the first singlet excited state among the other torsions around C=C or/and C—C bonds. In-plane flipping of the hydrogen attached to the nitrogen atom is also a less favorable geometrical variation in comparison with the C=N twisting for the  $S_1$  state.

(6) In the case of formaldimine and of allylidenimine the absorption into the  $n-\pi^*$  state will be followed by relaxation toward the minimum for the 90° twist around the C=N bond. A maximum of the rotation barrier in the ground state does not have to occur exactly at 90° twist. After rapid return to the ground state, the downhill relaxation in both directions for  $90^\circ < \theta < 90^\circ$  will proceed. Although the nonadiabatic coupling between  $S_0$  and  $S_1$  states has not been determined, it is expected that deviation from the Born–Oppenheimer approximation might have an important influence on the properties of these two states (cf. ref 8b).

(7) In the case of the twist around the C=C double bond in butadiene, the situation should be photochemically different as discussed in a related paper.<sup>16a</sup> The energy surface of the first singlet excited state of butadiene is flat, indicating the possibility of an additional minimum for twist angles  $< 90^\circ$ . If funneling through such a minimum to the ground state occurs, the photochemical yields of the two ground state isomers will not be equal.

(8) In the case of relaxed ethylene and butadiene, the first singlet excited state lies more than 70 kcal/mol above the ground singlet state. The ground state is of covalent nature throughout the twist interval and the first excited state is predominantly covalent or predominantly ionic in different regions, but it does not lose one of the leading features in the very narrow twist interval so that the nonadiabatic coupling between two electronic states is not a sharply peaked function (cf. ref 34). Consequently, in these cases rapid internal conversion to the ground state should not occur.

(9) Very large prolongation of the polyenic chain in the case of unprotonated Schiff bases might weaken the influence of the  $n-\pi^*$  transition<sup>35</sup> and of the charge transfer to the NH group so that the extremely favorable twist around the C=N bond in the first excited state of small unprotonated bases will become less favorable. The polarity of the ground state for the 90° twist angle might disappear and the energy gap between two lowest lying singlet states could become larger. Nevertheless, these effects do not have to be very strong in the case of medium-size unprotonated Schiff bases.

(10) In order to make some qualitative conjectures about the consequences of geometrical relaxation on the excited states of retinal, the properties of the protonated Schiff base are under investigation.

**Acknowledgment.** The support of the Deutsche Forschungsgemeinschaft in the form of Research Grant No. 627/4-2 is gratefully appreciated. The authors thank Professors J. Koutecký and J. Michl for many helpful discussions.

Registry No. Allylidenimine, 18295-52-8; formaldimine, 2053-29-4.

(34) M. Persico and V. Bonačić-Koutecký, *J. Chem. Phys.*, **76**, 6018 (1982).

(35) J. M. Leclercq and C. Sándorfy, *Photochem. Photobiol.* **33**, 361 (1981).